

General description

INNLABS' INN-203 tactical-grade accelerometers are used in commercial applications such as strap-down inertial navigation systems for aircraft, marine, land and others. Excellent performance of these accelerometers is achieved owing to proven quartz flexure technology. The INN-203 accelerometers can be supplied with integrated Bias and Scale Factor temperature models upon customer request. In addition to acceleration the INN-203 accelerometers also measure speed, distance, and obliquity.



Implementation of the latest advances in technology and economy of scale enable us to set lower price compared to other analogue accelerometers. Another substantial advantage is the fact that INNLABS purchasing process is simplified and hassle-free. These factors make INN-203 the №1 accelerometer on the tactical navigation market today.

Features

- Tactical performance – 200µg Bias Repeatability
- High Input Range – up to 50g
- High stability under temperature changes
- Analog output
- Compact design

Applications

- Inertial Navigation Systems for helicopters, manned and unmanned (UAV) aircrafts
- Navigation / orientation / gyrocompassing systems for naval vessels, ships, submarines, ROV, AUV
- Orientation systems for oil drilling industry

Accelerometer dimensions drawing (mm):

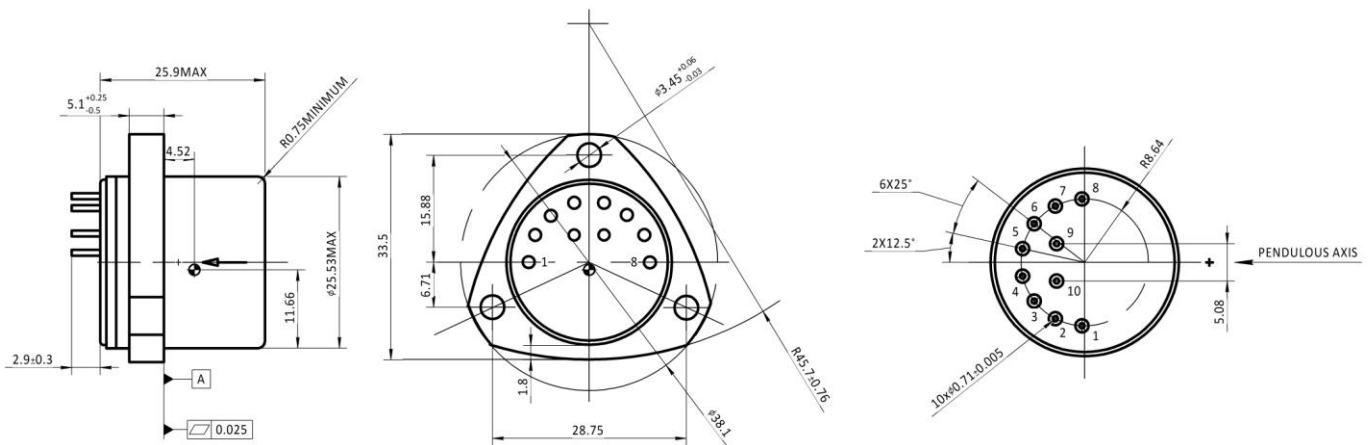

Technical Parameters

Parameters	Units	Values
Input Range	g	±50
Bias	mg	<20
One Year Repeatability	µg	<200
Temperature Sensitivity	µg/ degC	<100
Scale Factor	mA/g	1.0 ... 1.4
One Year Repeatability	ppm	<200
Temperature Sensitivity	ppm/degC	<200
Axis Misalignment	µrad	<2000
One Year Repeatability	µrad	<100
Non-linearity	µg/g ²	<100
Operating Temperature	degC	-55 ... +85
Vibration	g, Hz	8 g @ 20 ... 2000 Hz
Shock	g	70, 11ms
Resolution	µg	<5
Bandwidth	Hz	800
Current per Supply	mA	<16
Power @ ±15 VDC	mW	<480
Input Voltage	VDC	±12 ... ±18
Bias temperature model		Optional
SF temperature model		Optional
Size	mm	Ø 38.1 x 26
Weight	g	<80
Case Material		Stainless Steel

Connector PIN description:

PIN	Signal	PIN	Signal
1	Signal out	6	Temperature sensor output
2	Current torque	7	Voltage self test
3	-12 to -18 VDC	8	Signal and power return
4	+12 to +18 VDC	9	- 9VDC
5	NC	10	+ 9VDC

Disclaimer: the document is subject to change without notice. INNLABS reserves the right to make changes to any product or technology herein. INNLABS does not assume any liability arising out of the application or use of the product.